

Synopsis:

Dimension Prediction and Control for RTM Process

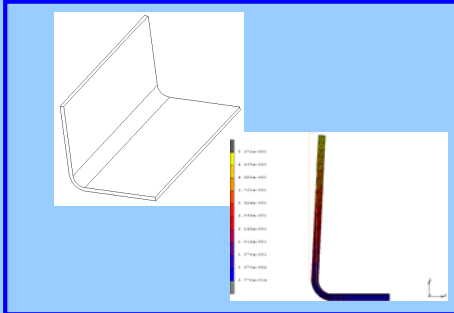

Prediction for spring-in for L-shaped part

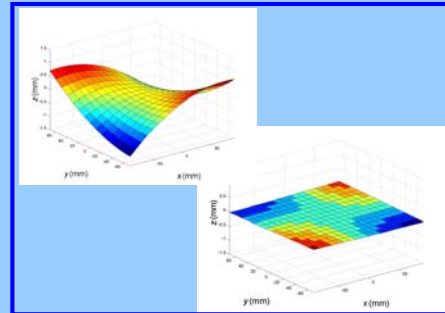

Part deformation before and after compensation

Background

Tight dimension tolerance is critical with the increasing demand for composite products to be affordable, net-shaped, and efficiently assembled. Due to a lack of accurate process models, RTM dimension analysis and control are often performed using trial-and-error approaches based on engineers' experiences or production data. Such approaches lack accuracy, require additional time, and are limited to specific geometry and materials. HPMI developed the deformation model based on the classical laminate theory (CLT) and the finite element analysis (FEA) method. The new approach provides a tool to predict and control dimension variations in the resin transfer molding (RTM) processes.

Goals

- Develop methodology and engineering tools for fabrication of high quality composite components through dimensional prediction and control at the design stage
- Validate the dimension prediction/compensation models with experiments
- Develop guidelines for composite part design to minimize part deformation

Projects/Research Highlights

- Develop a deformation model based on the classical laminate theory (CLT) and the finite element analysis (FEA) method
- Validate the simulation model with experiments
- Investigate deformations for typical composite part geometries

Benefits to Industry

- Composite parts with tight tolerances for seamless assembly
- Reduced costs associated with mold and/or part modifications
- Ensured part quality